

HYDRAULIC WINCHES ONE SPEED 18K

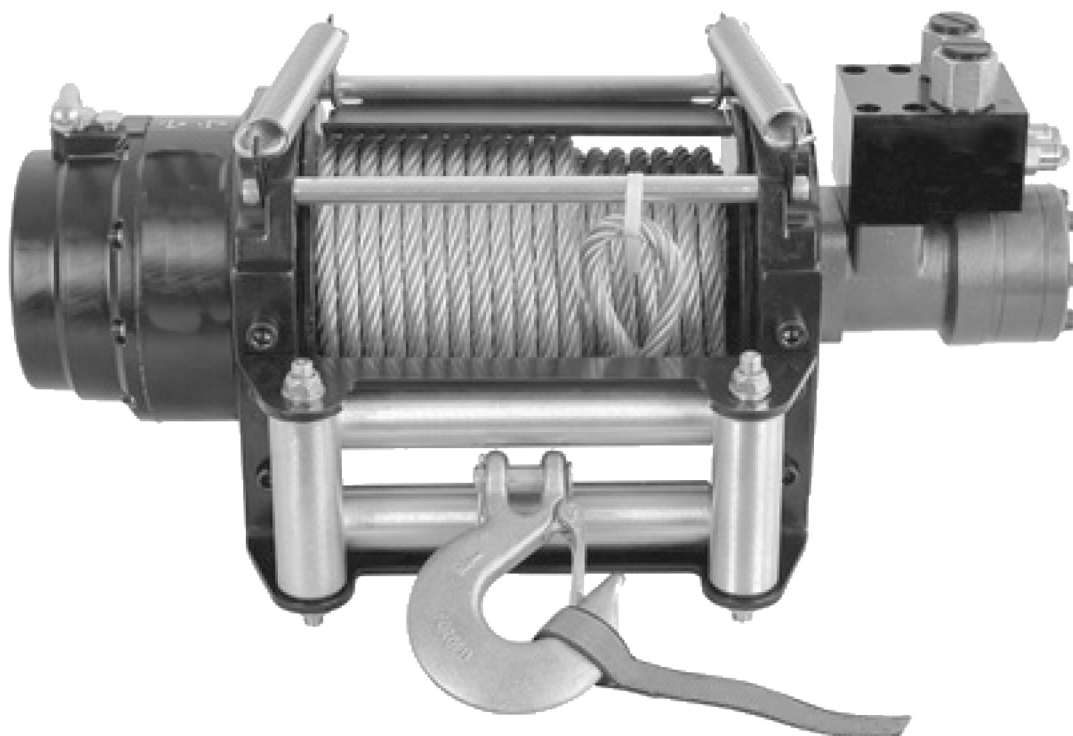

**MILE
MARKER**[®]
RECOVERYGEAR+

2121 Blount Road * Pompano Beach, Fla 33069 * USA
1-(954)-782-0604

WWW.MILEMARKER.COM

CE



**TO PREVENT SERIOUS INJURY, READ AND UNDERSTAND
ALL WARNINGS AND INSTRUCTIONS BEFORE USE.**

Due to continuing improvements, actual product may differ slightly from the product described herein.

Performance Data

Specifications

Model		9K	12K	15K	18
Line pull kg/lb		4,082 / 9,000	5,448 / 12,000	6,804 / 15,000	8,165 / 18,000
Line speed mpm/fpm		13.7 / 45	10.5 / 34.4	7.3 / 23.6	5.3 / 17.4
Operation pressure		140 bar/2,030 psi			
Max. Oil flow		20 USGPM / 75 L/min			
Motor	displacement	80.6 cm ³ /rev 4.9 in ³ /rev	80.6 cm ³ /rev 4.9 in ³ /rev	100.8 cm ³ /rev 6.2 in ³ /rev	124.9 cm ³ /rev 7.6 in ³ /rev
	rotation	Anti-clockwise	Anti-clockwise	Anti-clockwise	Clockwise
Gear train	type	2 stage planetary gear			
	Ratio	20.9:1	27.4:1	36:1	36:1
Brake		Heavy-duty automatic disc brake			
Wire rope diameter mm/in		9.53 / 3/8	10 / 29/64	12.7 / 1/2	12.7 / 1/2
Wire rope length m/ft		30.5 / 100	30.5 / 100	22 / 75	22 / 75
Wire rope breaking strength kgf/lbf		8900 / 19624.5	8900 / 19624.5	12091 / 26600	12091 / 26600
Safety hook		FESH05 (3/8")	FESH05 (3/8")	FESH04 (5/16")	FESH07(1/2")
Drum size		102x253mm(4x9.95")			
Net weight kg/lb		63 / 138.9	63 / 138.9	72 / 158.7	72 / 158.7

Line pull and speed at 20GPM(75L/min)

Model		9K	12K	15K	18K
1st layer	Line pull kg/lb	4,082/9,000	5,448/12,000	6,804/15,000	8,165/18,000
	Line speed mpm/fpm	13.7/45	10.5/34.4	7.3/23.6	5.3/17.4
	Rope cap m/ft	7.6/25	7.3/24	6.4/21	6.4/21
2nd layer	Line pull kg/lb	3,340/7,364	4,610/10,140	5,567/12,273	6,680/14,727
	Line speed mpm/fpm	16.3/25.5	12.4/40.7	8.7/28.9	6.5/21.3
	Rope cap m/ft	16.5/54	16.2/53	14/46	14/46
3rd layer	Line pull kg/lb	2,826/6,231	4,020/8,840	4,711/10,385	5,664/12,462
	Line speed mpm/fpm	18.9/62	14.4/47.2	10.4/23.1	7.8/25.6
	Rope cap m/ft	26.8/88	26.5/87	22.9/75	22.9/75
4th layer	Line pull kg/lb	2,449/5,400	3,570/7,850	-	-
	Line speed mpm/fpm	21.6/70.9	16.4/53.8	-	-
	Rope cap m/ft	38.4/126	38.4/126	-	-

mounting and overall dimensions:

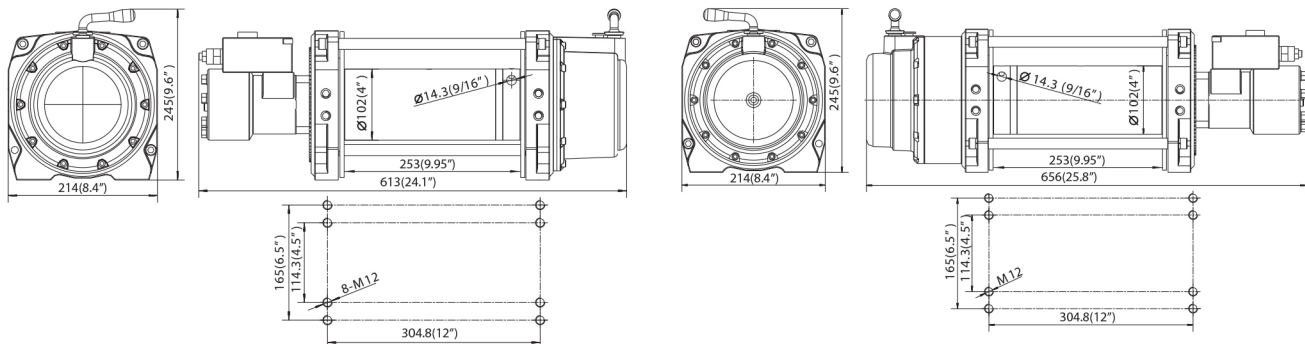

mounting and overall dimensions of 9F/ 12

mounting and overall dimensions of 15F/ 18

Unpacking

When unpacking, check to make sure all parts on the packing list are included. If there is any part missing, contact your local distributor.

Safety Warnings & Precautions

When using this winch, safety precautions should always be followed to reduce the risk of personal injury and damage to the winch.

LEARN TO USE THIS WINCH:

After winch has been installed, take some time and practice using it so you will be familiar with ALL OPERATIONS. Periodically check the winch installation to ensure that all bolts are tight. To ensure proper operation, carefully inspect for any damaged parts before operating the winch. Any damaged part should be properly repaired or replaced with identical parts by a qualified technician.

SECURE VEHICLE:

Secure vehicle in position before using winch. Apply blocks (such as a wheel chock) to vehicle when parking on an incline. Do not move vehicle with cable extended and attached to load to pull it. The cable could snap.

WORKING AREA:

Keep the working area well lit. Do not use this winch in the presence of flammable gases or liquids. Keep children away from working area. Never let children operate the winch. Do not allow people to remain in the area during winching operations.

INSPECT WIRE ROPE AND EQUIPMENT FREQUENTLY:

The wire rope should be inspected for damages that can reduce its breaking strength. A frayed rope with broken strands should be replaced immediately. Rope replacement must be rated to sustain the winch rated load. Any substitute must be IDENTICAL in strength, quality, Don't use unsuitable hook and snatch block for wire rope.

USE LEATHER GLOVES:

When handling or rewinding wire rope, always use hand protection to eliminate the possibility of cuts caused by burrs & slivers from broken strands.

DRUM ROPE:

Always make sure that there are at least 5 complete turns of rope left on the drum before winching.

KEEP HANDS AND FINGERS CLEAR OF WIRE ROPE AND HOOK WHEN OPERATING WINCH

Never put your finger through the hook when reeling in the last few feet. If your finger gets trapped in the hook or rope, you could lose it. Never guide a wire rope under tension onto the drum with your hand.

NEVER HOOK THE ROPE BACK ONTO ITSELF:

Hooking the rope back onto itself creates an unacceptable strain, breaking individual strands, which in turn weakens the entire wire rope.

KEEP PULLING DURATIONS AS SHORT AS POSSIBLE:

The winch is designed for intermittent use and cannot be used in constant duty applications. Do not pull more than one minute at or near rated load. If the motor becomes too hot to touch, stop and let it cool off for a few minutes. If the motor stalls, cut off the power immediately.

AVOID CONTINUOUS PULLS FROM EXTREME ANGLES:

This will cause the rope to pile up at one end of the drum. Fit the winch with the fleet angle no more than 15°. (See Fig.1)

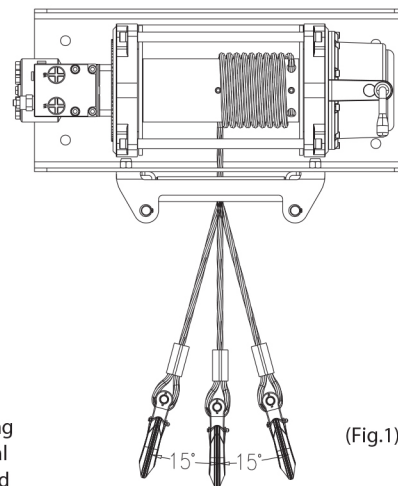

NEVER OPERATE THE WINCH WITHOUT THE ROPE FAIRLEAD FITTED: Operator injury or winch damage can happen if a fairlead is not installed.

DO NOT LIFT ITEMS VERTICALLY:

Do not use winch as a lifting device or a hoist for vertical lifting. The winch is designed for horizontal use only.

(Fig.1)

DO NOT MOVE PEOPLE:

Never lift people or hoist loads over people.

KEEP WINCHING AREA CLEAR:

Do not allow people to remain in the area during winching operations. Do not step over a taut wire rope or allow anyone else to do so. Never come in between the winch and the load when operating. Due to the possibility of a wire rope breaking, lay a heavy blanket over the wire rope near the hook end and direct all persons to stand clear of any possible pathways.

SECURE THE ITEM:

Winch does not have a locking mechanism. Secure load after moving. Do not rely on the winch to hold it for an extended period.

STAY ALERT:

Watch what you are doing. Use your common sense. Do not use this winch when you are tired, stressed or when under the influence of drugs, alcohol or medication.

DISCONNECT SWITCH:

Re-spool cable properly and unplug switch when not in use.

REPLACEMENT PARTS & ACCESSORIES:

When servicing, use only identical replacement parts. Use of any other parts will void the warranty.

Installation

Before using the winch, make sure all components have no corrosion or defect; the environment should be clear and dry.

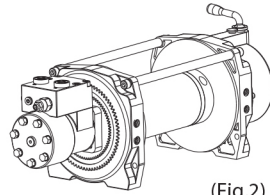

(Fig.2)

INSTALLATION INSTRUCTION For The Remote Clutch Kit

1. The clutch lever should always travel through a 180 degree arc from "Engaged" to "Free Spool" position as shown in Fig.3.

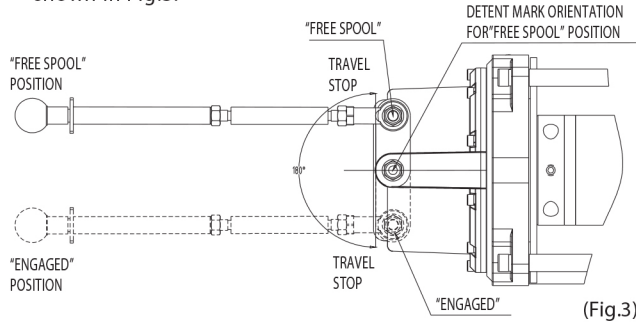

(Fig.3)

2. Bolt the lock plate to an appropriate mounting surface. (NOTE: Bolts for mounting the lock plate are not provided.) (See Fig.4)

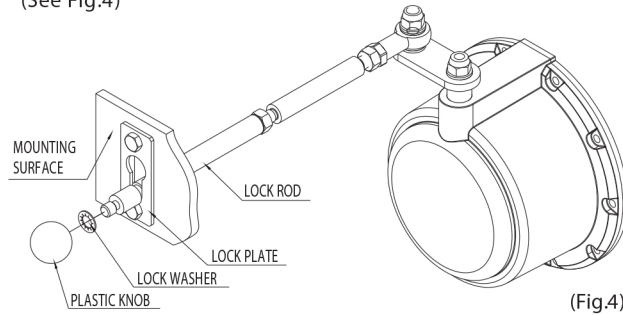

(Fig.4)

3. Screw the plastic knob onto the lock rod using the lock washer provided. (See Fig.4)
4. Although the clutch rod is not provided with the kit, the rod length can be determined by measuring the distance between the lock rod and the ball joint rod end. The clutch lever should be in the "Engaged" or "Free Spool" position. Make allowance for the length of thread needed in the lock rod and rod end. Use M10 Thread Size for Remote Clutch Kit.
5. Thread the clutch rod into the ball joint rod end and tighten with the appropriate hex nut. Attach the lock rod to the clutch rod and lock with the hex nut. (See Fig.5). Adjust the length of the clutch rod so the clutch lever travels through the correct arc. (See Fig.3). The clutch lever must not be forced past the travel stop, since this will result in internal damage to the unit.

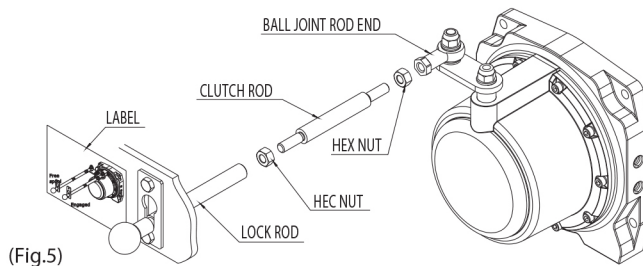

(Fig.5)

Warnings

Test the operation of the assembly. The control should move freely through the correct travel arc; there should not be interference between the lock nuts on the clutch shaft and clutch rod. The decal can be applied to the mounting surface as shown in Fig.5, only if the clutch is "Engaged" with the control pushed in. (See Fig.3)

Mounting

1. It is very important to have the winch mounted on a hard surface with a surface flatness 0.5 mm in order to make sure the motor, drum and gearbox housing are aligned correctly. Failure to the alignment could have negative effect on winch performance and even damage the winch.
2. A minimum of 6 mm thick (for RYW09) and 7 mm thick (for RYW18) steel Mounting Channel is absolutely required to prevent the possibility of damage to the winch or vehicle.
3. The winch should be mounted as close to center and as perpendicular as possible to the direction of the line pull. This will keep the wire rope fleet angle centered on the drum as small as possible.
4. The tie bars supplied with the winch must remain attached when winch is foot mounted. Unless a roller fairlead is used, one of tie bar can be removed.
5. The Roller fairlead does not mount to winch directly.
6. All the eight (8) M12 X 35, 8.8 grade high tensile steel bolts must be used for RYW09 and RYW18 in order to sustain the loads imposed on the winch mounting.

Free-spool Function:

The free-spool allows rapid unwinding of the wire rope for hooking onto a load or anchor points and is operated by a handle. The Clutch Handle must be in the "Engaged" position before winching.

1. To free-spool, press the lock-button down and turn the Clutch Handle clockwise at 180° to the "free-spool" position. Release the lock-button to its lock position. Now wire rope can be free spooled from the drum. (See Fig.6)
2. To engage, press the lock-button down and turn the Clutch Handle counter-clockwise at 180° to the "Engaged" position. Release the lock-button to its lock position. (See Fig.7)
3. If the clutch handle can't be properly locked in the "Engaged" position, rotate the drum to make the gear train coupling easier.
4. Wear leather gloves and use a hand-saving strap when pulling the wire rope out of the drum.

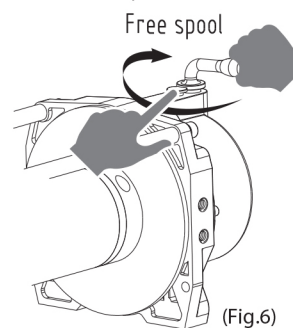

(Fig.6)

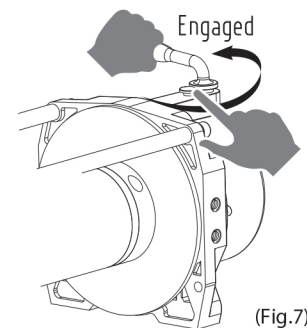

(Fig.7)

Hydraulic system installation

Powered by PTO(power-take-off) unit.

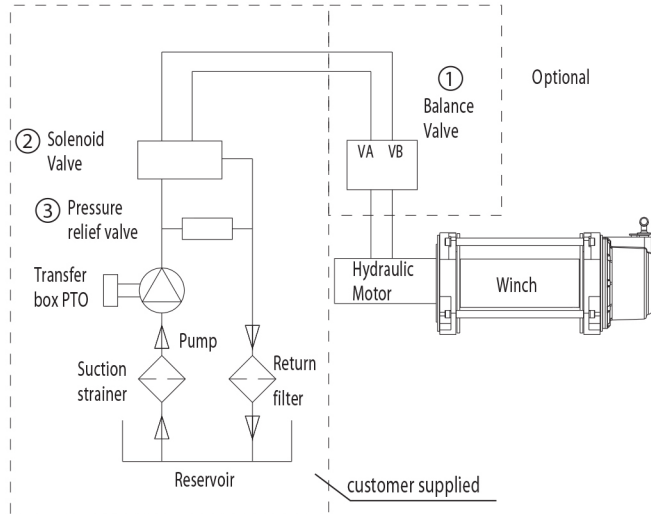

Pump: With a max. oil supply of 20 USGPM / (75 L /min) at top motor rpm.

The pump must be capable of delivering a pressure of 170 bar (2,466 psi)

Reservoir: Must be fitted with an oil filler device comprising strainer and filter and a dip stick. The capacity of the tank should be at least 80 liters.

Hoses: Inlet line ... 1-1/4"—1-1/2" nominal bore (N.B.) from reservoir to pump

Return line ... 1" (N.B.) from solenoid valve to reservoir

Pressure hoses3/4" (N.B.) from solenoid valve to balance valve

Balance valve drain line pipe: 1/4" BSP N.B.

solenoid valve: 4 way, 3-position with spring centered, open centre

Hydraulic motor: Heavy, industrial and long periods used OMRZ80 for RYW09F,RYW12, OMRZ100 for RYW15F,OMRZ125 for RYW18

It is recommended to have the motor drain line connected back to the reservoir

As a general rule

The hydraulic system shown above must contain solenoid valve (2) and pressure relief valve (3) for having the winch operated correctly. The balance valve (1) is optional. If your winch installed without the balance valve, NEVER POWER WINCH CABLE OUT WITH HEAVY LOAD. Failure to use the correct valves may result in damage to the winch, property, or personal injury.

The relief valve must be set at the winch operating pressure and does not exceed the rated pressure. Failure to use the correct pressure and flow may result in damage to the winch, property or personal injury.

The hydraulic pressure or flow lower than those rated for the winch may result in a lower line pull or lower line speed.

The bigger nominal bore hose, the better winch performance.

Keeping cleanliness and accuracy on the hydraulic system installation is essential to have hydraulic system functioned properly

All hose lengths should be kept to a minimum because pressure and flow loss is increased as hose length increases

Pressure and return lines in excess of 3.5 meter (11.5") should be compensated with an increase in nominal bore size

Hydraulic System Specification

System type: Open system with filtered return line

Balance valve: Give smoothly controlled winch out when under load and to provide full dynamic braking. It must be installed to hold full load

Port VA means the inlet port of oil from reservoir.

Port VB means the return port of oil to reservoir.

Relief valve: Set at the winch operating pressure

Operation

Warnings

1. Make sure clutch is totally engaged before starting any winch operation;
2. Stay clear and away from raised loads;
3. Stay clear of cable while pulling. Do not try to guide cable.
4. A min. of 5 wraps of cable around the drum barrel.

1. Dis-engage the clutch by turning the Clutch Handle clockwise to "FREE SPOOL" position.(See Fig.6)
2. Grab the wire rope assembly hook with a hand-saving Strap and pull the wire rope to the desired length, then attach to item to be pulled.

Caution: always leave at least five turns of cable on the drum; review winch safety warnings and precautions on page 2,3 before continuing.

3. Re-engage the clutch by turning the Clutch Handle anti-clockwise to "ENGAGE" position. If necessary, turn the drum till to hear a slight click sound showing fully engaged. then finger the clutch tight.(See Fig.7)
4. With different selection of accessories, winch operation will be different.

Maintenance

Trouble shooting

SYMPTOM	POSSIBLE CAUSE	SUGGESTED ACTION
Which does not turn	-Electrical connections have not connected properly (For winch installed with Electricmagnetic Valve only)	-Insert switch assembly all the way into connector. -Tighten nuts on all cable connections.
Motor runs but cable drum does not turn	-The clutch is not engaged	-turn the clutch to engage in position fully. If problem still persists, a qualified technician is needed to check and repair.
Winch drum runs slowly or without normal power.	-insufficient pressure or oil flow -balance valve connected with wrong direction. -insufficient fluid in the system.	-Pump is not suitable or defective. Change a new one or a suitable one. -Disconnect the balance valve; exchange the oil hole of the balance valve. -Check fluid level.

Lubrication:

1. All moving parts within the winch having been lubricated using high temperature lithium grease at the factory. No internal lubrication is required.
2. Lubricate cable assembly periodically using a light penetrating oil.

Wire Rope Replacement

Before installing a new wire rope, wrap the end of the wire rope with tape to prevent fraying. Wind the wire rope on the drum by pull a force to keep the tension constant. Never use a wire rope of a different size or material and only use genuine wire ropes.

1. Disengage the free-spool.(See Fig.3)
2. Pull out the old wire rope, and then remove it from the drum.
3. Take horizontal roller and bolts of roller fairlead apart, then place the replacement wire rope through the roller fairlead opening, pass below the drum, and insert it into the hole on the drum core.
4. Use a hex wrench to tighten the screw downwards to secure the wire rope.
5. Tighten the horizontal roller and bolt of roller fairlead
6. Wear leather gloves and use a strap when guiding the wire rope off/on the drum.

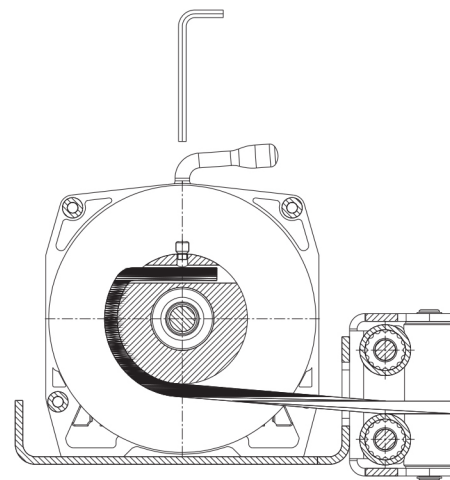

Assembly Drawing For 9F/ 12

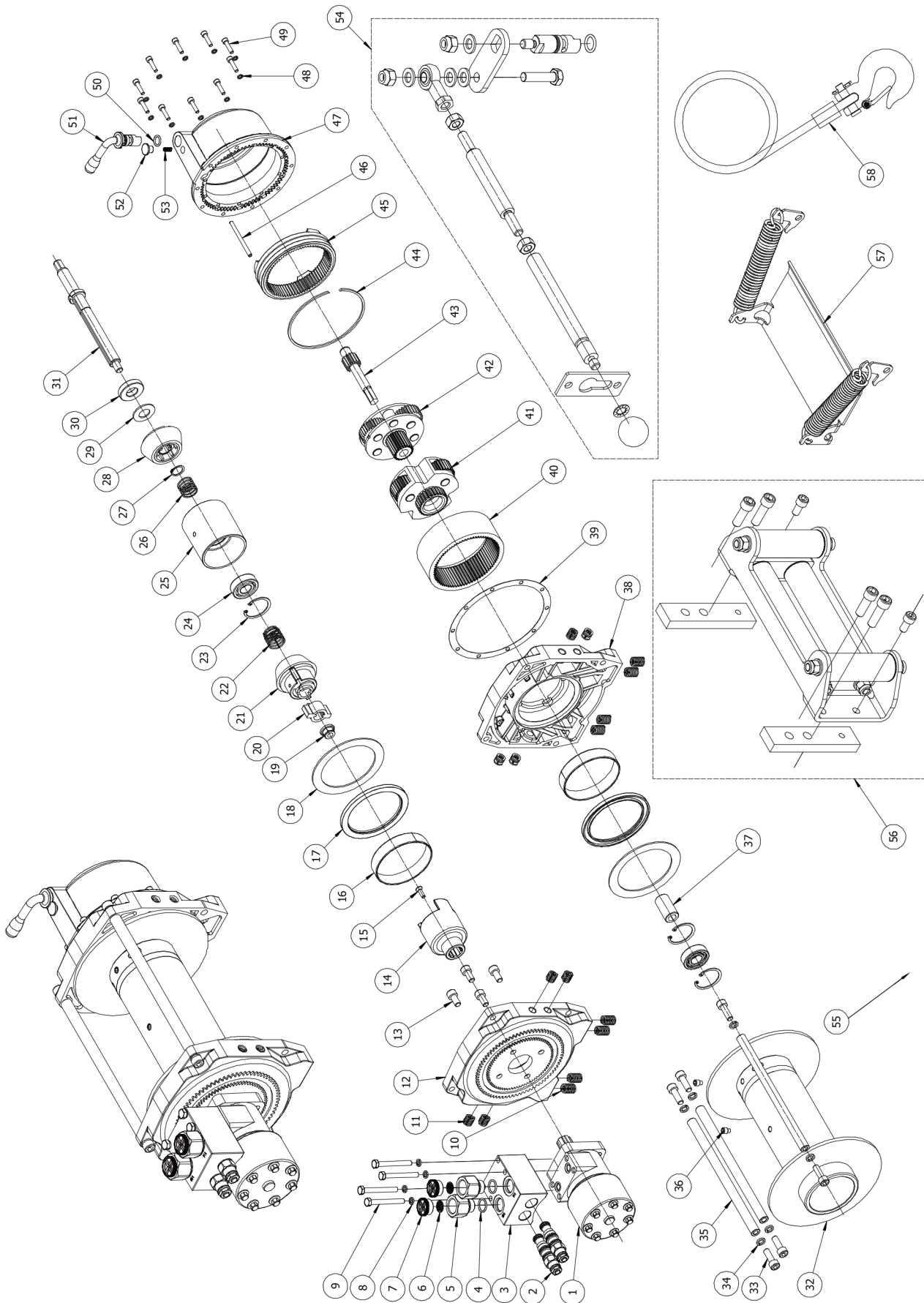

Replacement parts list For 9F/ 12

Item	Description	Qty	Item	Description	Qty
1	Hydraulic motor	1	30	Bushing	1
2	Counterbalance cartridge valve (Optional)	2	31	Brake shaft	1
3	Valve plate (Optional)	1	32	Drum	1
4	O-ring 19.18x2.46 (Optional)	2	33	Screw M10x30	6
5	Filter joint	2	34	Spring Washer 10	6
6	The filter assembly	2	35	Tie bar	3
7	cap (Optional)	2	36	Set screw M10x14	2
8	Spring Washer 8 (Optional)	4	37	Hex connecting socket	1
9	Screw M8x70 (Optional)	4	38	Gear support rack	1
10	wire thread insert 12x1.75x12	8	39	Gasket	1
11	wire thread insert 12x1.75x8	8	40	2nd ring gear	1
12	Motor support rack	1	41	2nd gear carrier	1
13	Screw M10x20	4	42	1st gear carrier	1
14	Connecting socket	1	43	1st sun gear	1
15	Screw 1/4"-20x3/4"	1	44	circlips for hole	1
16	oilless bearing	2	45	1st ring gear	1
17	VC oil seal	2	46	Pin 6x81	1
18	PTFE washer	2	47	Gear box	1
19	Lock nut M12	1	48	Spring Washer 6	10
20	driver	1	49	Screw M6x25	10
21	spiral assembly	1	50	O-ring 14x2.65	1
22	Brake spring	1	51	Clutch handle (Optional)	1
23	circlip 47	3	52	Locked button (Optional)	1
24	deep groove ball bearing 6204-2Z	2	53	Handle spring (Optional)	1
25	brake block	1	54	Remote clutch kit assembly(Optional)	1
26	compression spring	1	55	Handle strap	1
27	circlip 20	1	56	Roller failead assembly (Optional)	1
28	friction plate assembly	1	57	Wire rope tensioner kit (Optional)	1
29	Disc spring A40-2	1	58	Cable assyembly	1

Assembly Drawing For 15F/ 18

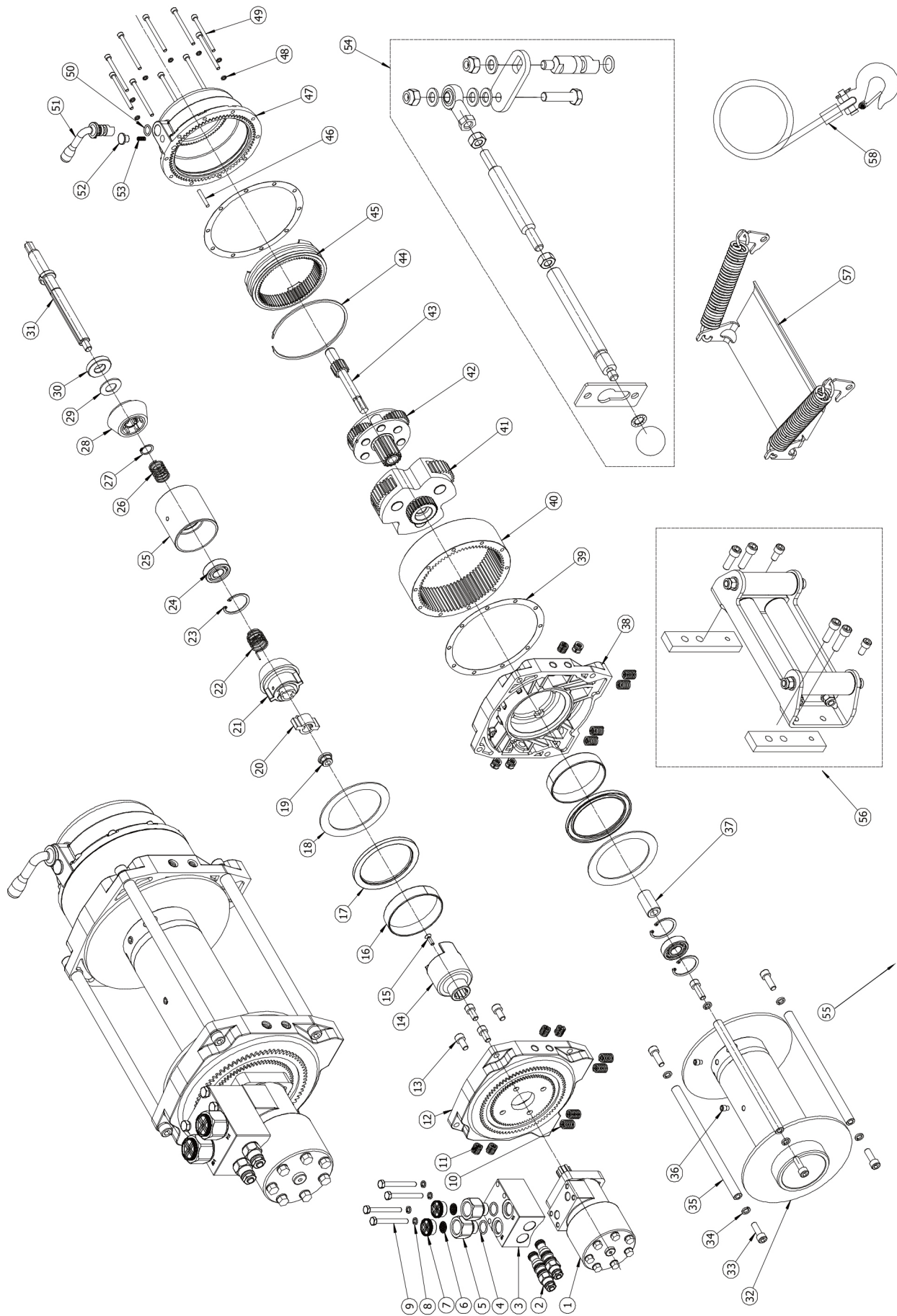

Replacement parts list For 15F/ 18

Item	Description	Qty	Item	Description	Qty
1	Hydraulic motor	1	30	Bushing	1
2	Counterbalance cartridge valve (Optional)	2	31	Brake shaft	1
3	Valve plate (Optional)	1	32	Drum	1
4	O-ring 19.18x2.46 (Optional)	2	33	Screw M10x30	6
5	Filter joint	2	34	Spring Washer 10	6
6	The filter assembly	2	35	Tie bar	3
7	cap (Optional)	2	36	Set screw M10x14	2
8	Spring Washer 8 (Optional)	4	37	Hex connecting socket	1
9	Screw M8x70 (Optional)	4	38	Gear support rack	1
10	wire thread insert 12x1.75x12	8	39	Gasket	1
11	wire thread insert 12x1.75x8	8	40	2nd ring gear	1
12	Motor support rack	1	41	2nd gear carrier	1
13	Screw M10x20	4	42	1st gear carrier	1
14	Connecting socket	1	43	1st sun gear	1
15	Screw 1/4"-20x3/4"	1	44	circlips for hole	1
16	oilless bearing	2	45	1st ring gear	1
17	VC oil seal	2	46	Pin 6x38	1
18	PTFE washer	2	47	Gear box	1
19	Lock nut M12	1	48	Spring Washer 6	10
20	driver	1	49	Screw M6x25	10
21	spiral assembly	1	50	O-ring 14x2.65	1
22	Brake spring	1	51	Clutch handle (Optional)	1
23	circlip 47	3	52	Locked button (Optional)	1
24	deep groove ball bearing 6204-2Z	2	53	Handle spring (Optional)	1
25	brake block	1	54	Remote clutch kit assembly(Optional)	1
26	compression spring	1	55	Handle strap	1
27	circlip 20	1	56	Roller failead assembly (Optional)	1
28	friction plate assembly	1	57	Wire rope tensioner kit (Optional)	1
29	Disc spring A40-2	1	58	Cable assyembly	1