

INSTALL INSTRUCTIONS



TRAIL CREEPER™ 4.24 T-CASE REDUCTION GEAR KIT

302883-3-KIT

KIT CONTENTS

1 CT.

4.24:1 Gear set
Tube Ultra grey silicone
T-Case input seal

2 CT.

T-Case output seal





RECOMMENDED TOOLS

Metric Socket Set
Gasket Scraper
Mallet
Shop Press
Flat Blade Screwdriver
Phillips Screwdriver
Box End Wrench Set
Angle Grinder
Snap Ring Pliers
Punch Set
Hammer
Gear Puller
Bearing Separator
Magnetic Pick Up Tool

CAUTION

1. Read all instructions completely and carefully before you begin. If anything is not clear, please call our tech support line at 1.877.4X4.TOYS or 559.252.4950 before proceeding.
2. Check to make sure the kit is complete and that no parts are missing (refer to the Kit Contents Section on the first page of these instructions). If anything is missing, please contact Trail-Gear at 1.877.4X4.TOYS or 559.252.4950.
3. This kit is for off-road use only. It is recommended that the installation steps below be performed by a competent mechanic. Buyers and users of this product hereby expressly assume all risks associated with the installation and use of this kit.

INSTALL INSTRUCTIONS (CONT'D.)



STEP 1

Begin by removing transmission and transfer case assembly from vehicle. This is necessary as one of the bolts connecting the transfer case to transmission is located under the transmission shifter.

STEP 2

Remove transmission shifter base. Now transfer case can be unbolted from the transmission.



STEP 3

Begin transfer case disassembly by removing the 4WD drive light switch and steel ball that rides under it.

STEP 4

Remove transfer case shifter base.



STEP 5

Remove shifter return spring and ball as shown.

STEP 6

Using a punch remove the roll pin that holds the shift yoke in place, and remove the shift yoke.

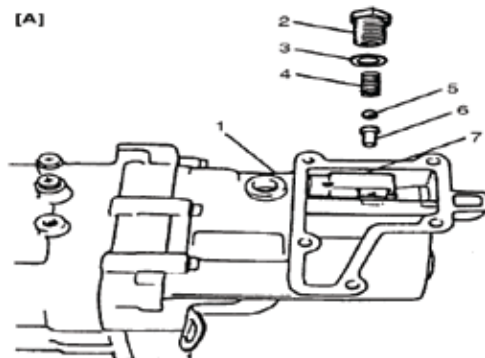

INSTALL INSTRUCTIONS (CONT'D.)



STEP 7

Remove 15 bolts holding rear housing in place. The rear housing may now be removed.



STEP 8

Depending on model, the speedometer drive gear may be held in place by a locking ball. Be careful not to lose this when removing the speedometer driver gear.



STEP 9

Remove c-clip on main shaft using two screw drivers and a hammer.

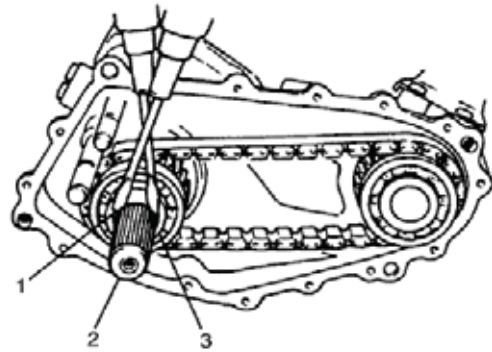

STEP 10

Depending on the model, there may be factory shims underneath certain bearings. These must be re installed in the same location.



STEP 11

Remove main bearing using a bearing puller.



STEP 12

Now the bushing, needle bearing, chain drive gear, chain, and locking ball can be removed. Be careful not to lose the locking ball. Some models have an oil baffle. If so, remove oil baffle at this time.



INSTALL INSTRUCTIONS (CONT'D.)



STEP 13

Remove counter shaft locking tab.



STEP 14

Remove 9 bolts holding front cover in place and remove the cover.



STEP 15

If the input support bearing did not come out with the input, remove it from the main shaft.



STEP 16

Remove counter shaft with gear and needle bearings as a single unit.

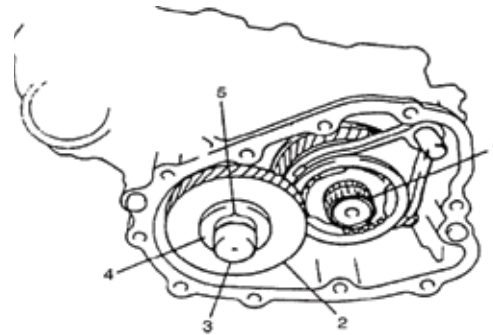

STEP 17

Remove high/low shift detent assembly. Make sure transfer case is in 4wd and remove high/low shift rail, shift fork and shift collar as a single unit. During this step it is possible for the interlock ball to fall out from between the shift rails, be careful not to lose it.

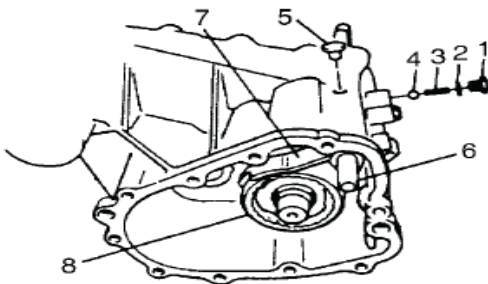

STEP 18

Remove 4WD shift detent assembly. Pull out 4WD shift rail, shift fork and shift collar as a single unit. Note which orientation the collar was in when removing it as it will need to be reinstalled in the same orientation. During this step it is possible for the interlock ball to fall out be careful not to lose it.

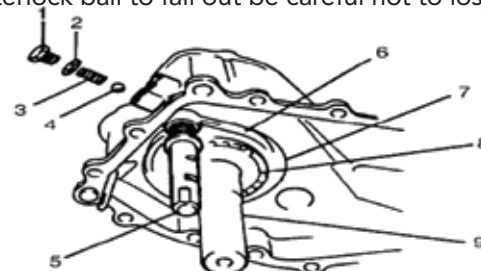

INSTALL INSTRUCTIONS (CONT'D.)



STEP 19

The main shaft can be removed using a rubber mallet.

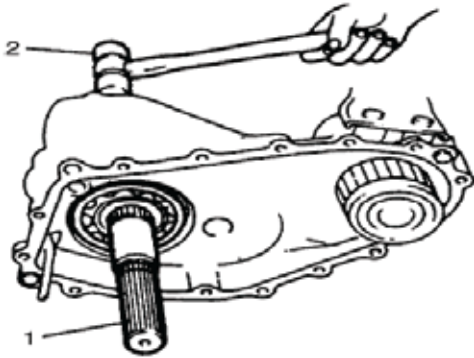

STEP 20

Remove c clip. Using a press and bearing puller remove the reduction hub and low speed gear.

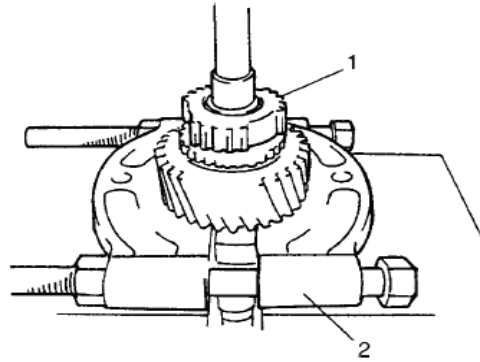

STEP 21

Remove c clip from input gear, using mallet remove input gear and bearing from front housing.

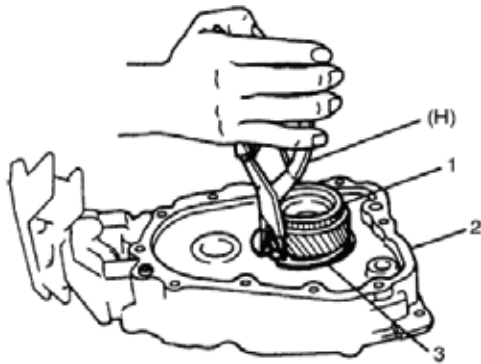

STEP 22

Remove c clip from input gear and press the bearing off.

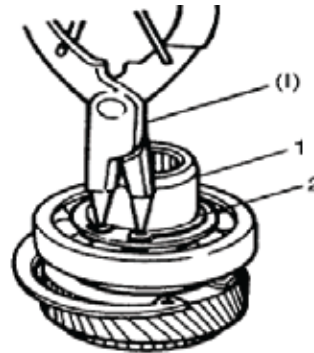

STEP 23

Check bearing for damage and replace if needed. Re-install the bearing onto the new input gear then re-install the inner snap ring.



STEP 24

Remove input and both output seals from the housings, and replace with the included seals.



INSTALL INSTRUCTIONS (CONT'D.)



STEP 25

Reinstall the new input gear back into the front cover and secure it with the inner snap ring.



STEP 26

Grease the main shaft needle bearing, slide the needle bearing and low range output gear into place.



Note: Clean the packing oil out of the oiling hole of the low range output gear. Bearing damage will result if oiling hole filled with packing oil.

STEP 27

Press on the reduction hub and install the inner snap ring.

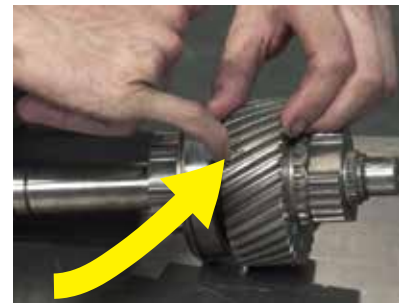

STEP 28

At this point the case will need to be cleared for the larger low range output gear and the counter shaft gear. Be sure to thoroughly remove any metal shavings created during clearance.

STEP 29

MAIN SHAFT INSTALL: The low speed gear is now larger in diameter, and will no longer fit through the main bearing hole. To install, remove the outer snap ring on the main bearing and install the main shaft from the opposite side it was removed from.

STEP 30

Area to clearance for low range output gear.



STEP 31

Area to clearance for counter shaft gear.



STEP 32

Re install the main shaft into center transfer case housing and install main bearing snap ring. Ensure that low range output gear spins freely and does not make contact with case.



STEP 33

Install counter shaft assembly into center housing and verify that gear spins freely without contacting case. Assemble Front case housing onto center case and verify that the gear does not make contact. Remove front housing and counter shaft assembly.

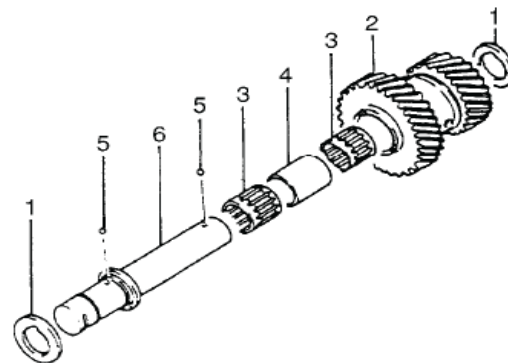

INSTALL INSTRUCTIONS (CONT'D.)



STEP 34

Now that all clearances have been checked, install the counter shaft assembly into the front cover assembly in the following steps.

STEP 34A

Note position of locking ball groove.



STEP 34B



STEP 34C

Note locking ball location when installing counter shaft. Install the thrust washer (note oil gally grooves face the gear).



STEP 35

Install 4WD shift fork and collar over hub.



INSTALL INSTRUCTIONS (CONT'D.)



STEP 36

Install 4WD detent assembly.



STEP 37

Insert the bushing locking ball into shaft, secure using a dab of grease.

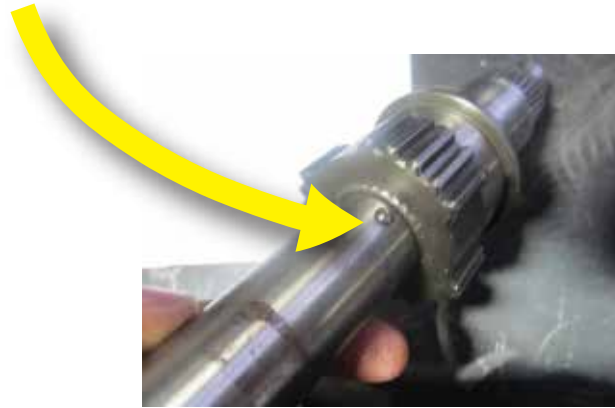

STEP 38

Grease needle bearing and install bushing, needle bearing, and chain drive gear onto main shaft.



STEP 39

Now install the front output and drive chain.



STEP 40

Support main shaft and press bearing onto shaft and install C-clip.



INSTALL INSTRUCTIONS (CONT'D.)



STEP 41

Install speedometer drive gear. Depending on model the speedometer drive gear may either be held in place by the output splines or by a locking ball. Install C-Clip.



STEP 42

Install interlock ball.

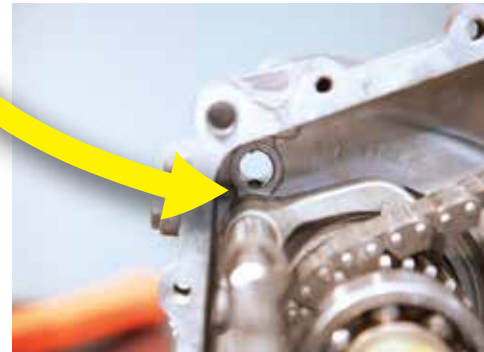

STEP 43

Install high/low shift rail and detent assembly into housing, 4WD shift rail must be in 4WD.

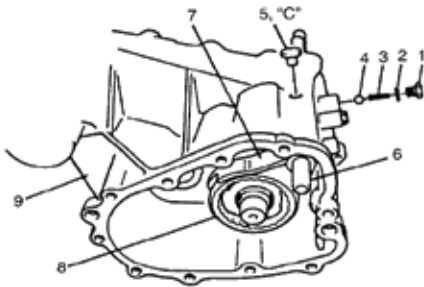

STEP 44

Reinstall input needle bearing



STEP 45

Apply thin layer of silicone gasket material and mate front housing onto center housing. Install bolts and tighten. Re-install the counter shaft locking tab and bolt.



INSTALL INSTRUCTIONS (CONT'D.)



STEP 46

Reinstall shim that was present in transfer case. The factory service manual documents measuring for and selecting a shim. In our builds we have not found it necessary to choose a new shim.



STEP 47

Apply thin layer of silicone to rear housing and mate with center housing. Install and tighten bolts.



STEP 48

Slide shift yoke and shift yoke pin onto shift rail and secure with roll pin.



STEP 49

Reinstall shifter return spring and ball.

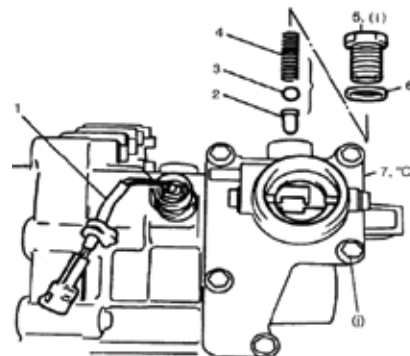

STEP 50

Install shift light switch and ball.

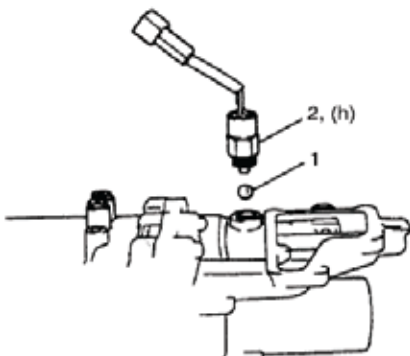

STEP 51

Apply thin layer of silicone to shifter base. Install shifter base and shifter and check for smooth operation, to engage 4WD the input/outputs may need to be spun by hand.



INSTALL INSTRUCTIONS (CONT'D.)



STEP 52

Once proper operation is ensured remove shifter from base.

STEP 53

Bolt transfer case onto transmission.

STEP 54

Apply thin layer of silicone to transmission shifter base and reinstall.

STEP 55

Reinstall transmission/transfer case assembly into vehicle.



STEP 56

Change transfer case oil after the first 500 miles of use.

INSTALL INSTRUCTIONS (CONT'D.)



REPLACEMENT PARTS

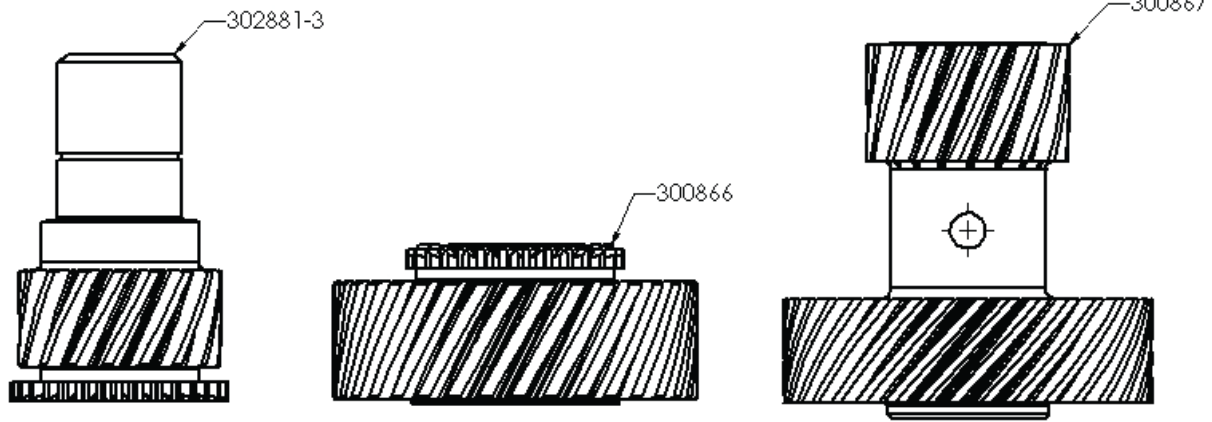

P/N	DESCRIPTION
302554	SEAL,TCASE,OUTPUT,SIDEKICK,91-98
302555	SEAL,TCASE,INPUT,SIDEKICK,91-98